

DETAIL & SUBMITTAL SHEET



SPECIFICATIONS:

- Heavy-duty steel construction
- Flow-coated, baked-on factory prime finish
- Corrosion-resistant zinc-plated, chromate-sealed hardware
- Torsion Cam Lift system provides easy, one-hand operation
- Slide bolt locking mechanism (optional keyed lock available)
- Flanged construction and J-channel header shed water and prevent binding due to ice and snow, permitting all season use
- Extensions are available to increase the door length for sizes Ultra and Classic Series Door
 - Classic Series: 6", 12", 18" and 24" lengths
 - Ultra Series: 6" and 12" lengths only

Two or more extensions can be mounted back to back for longer extensions.

CONSTRUCTION FEATURES:

- 1 Discard your old door and measure (in inches) the dimensions of the areaway foundation.
- 2 Measure dimension W1, the inside width, and dimension W2, the outside width of the areaway foundation walls. Record your dimensions and make the calculation shown.
- 3 Measure dimension L1, the inside length, and dimension L2, the outside length of the areaway foundation walls. Record your dimensions and make the calculation shown.
- 4 Measure dimension H1, the height from the top of the areaway foundation to the top of the opening in the house foundation.

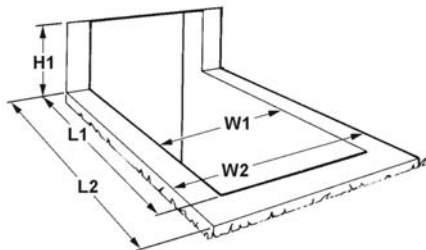

OPTIONS: (AT EXTRA COST)

Keyed lock

✓	Item No.	Size in inches W x L x H
	WB Classic C	55 x 72 x 19 1/2

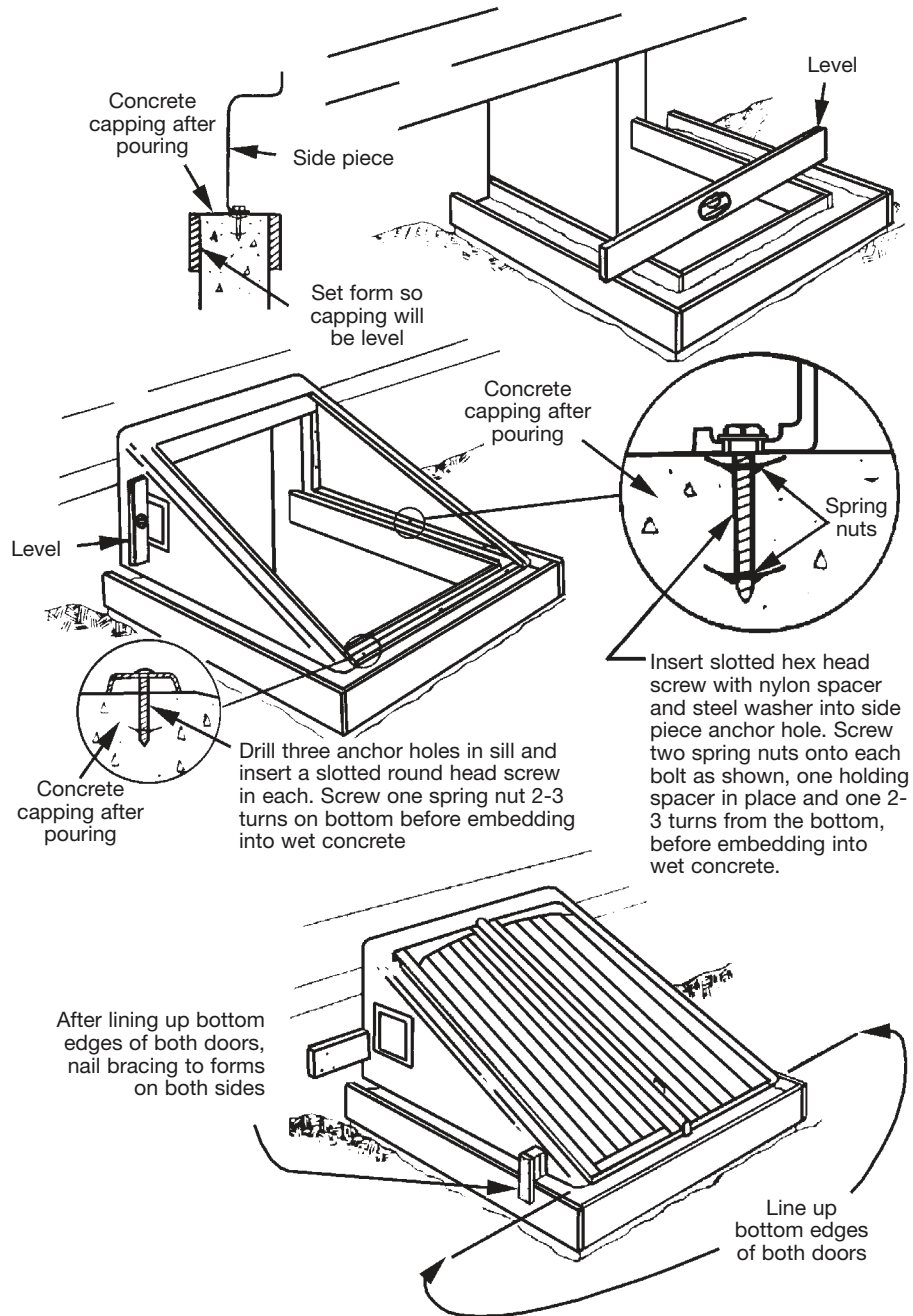

Project: _____ Date: _____

Contractor: _____ Architect: _____

Sizes: _____ Quantity: _____ Approval Initials: _____



Phone: 1-800-255-5515 • Fax: 1-800-822-5001

www.wbdoors.com