

**DETAIL & SUBMITTAL SHEET**

**SPECIFICATIONS:**

**WB Safety Grab:** 3/4" heavy ga. steel that attaches to the roof hatch

- For added and improved safety whether entering or leaving the roof
- Overall height 17", horizontal width 10" to corner
- Textured for increased grip
- Easily mounted on either corner of exterior hatch opening
- Polyester dry powder coated to match roof access hatch

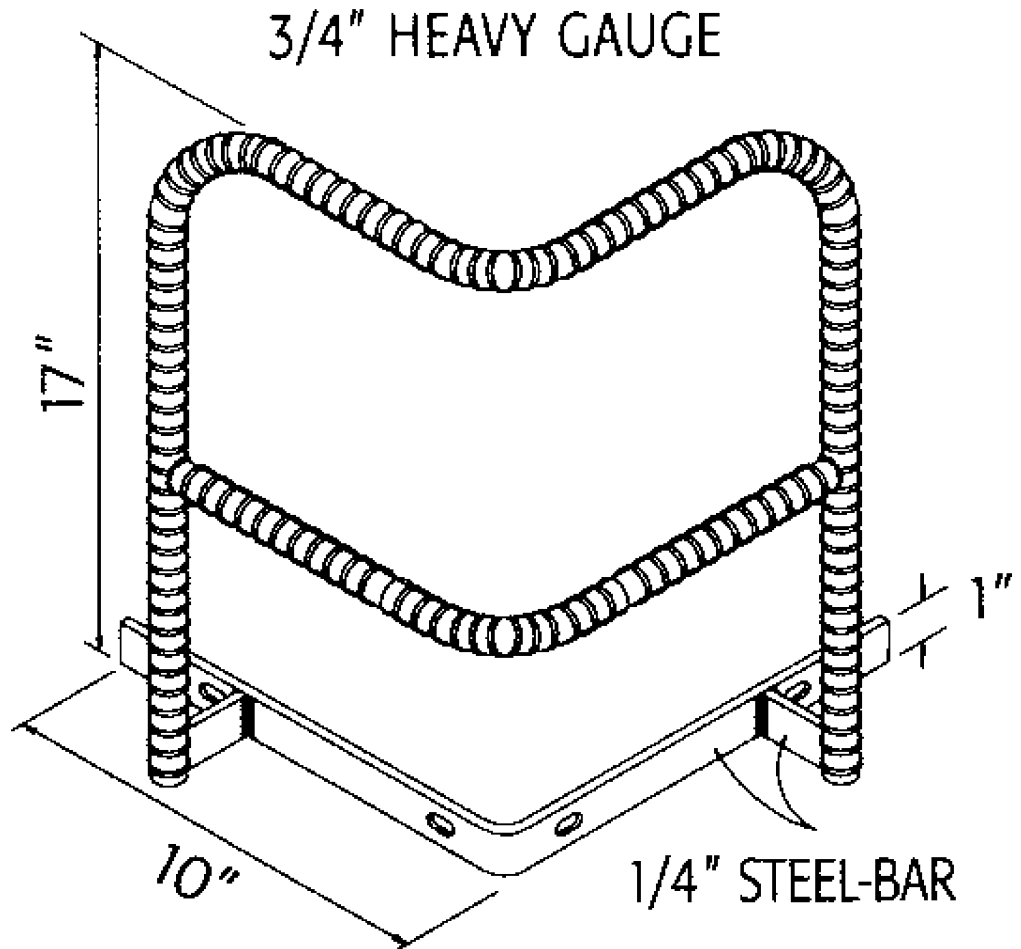

✓	Item No.	Material	Ship Wt. Lbs.
	WB Safety Grab*	Steel	-

\* Stock item

Project: \_\_\_\_\_ Date: \_\_\_\_\_

Contractor: \_\_\_\_\_ Architect: \_\_\_\_\_

Sizes: \_\_\_\_\_ Quantity: \_\_\_\_\_ Approval Initials: \_\_\_\_\_

**W** The Williams Bros. Corporation of America

Phone: 1-800-255-5515 • Fax: 1-800-822-5001

**www.wbdoors.com**