

## DETAIL & SUBMITTAL SHEET

### SPECIFICATIONS:

**WB Safety Posts** provide easier, safer ladder access through roof hatches, floor, vault, and sidewalk doors, and manholes.

This telescoping post permanently mounts to the top two rungs of any fixed ladder, providing a positive hand-hold and enabling the user to enter or exit an opening in an upright and balanced position.

- Adjustable mounting hardware accommodates virtually any ladder rung size or spacing.
- Telescoping design is spring balanced for ease of operation.
- Automatically locks in the fully raised position to provide the user with a firm and steady hand-hold.
- Handy release lever allows the post to be easily lowered to its retracted position.
- Available in four levels of corrosion resistance to provide many years of trouble free, dependable service.

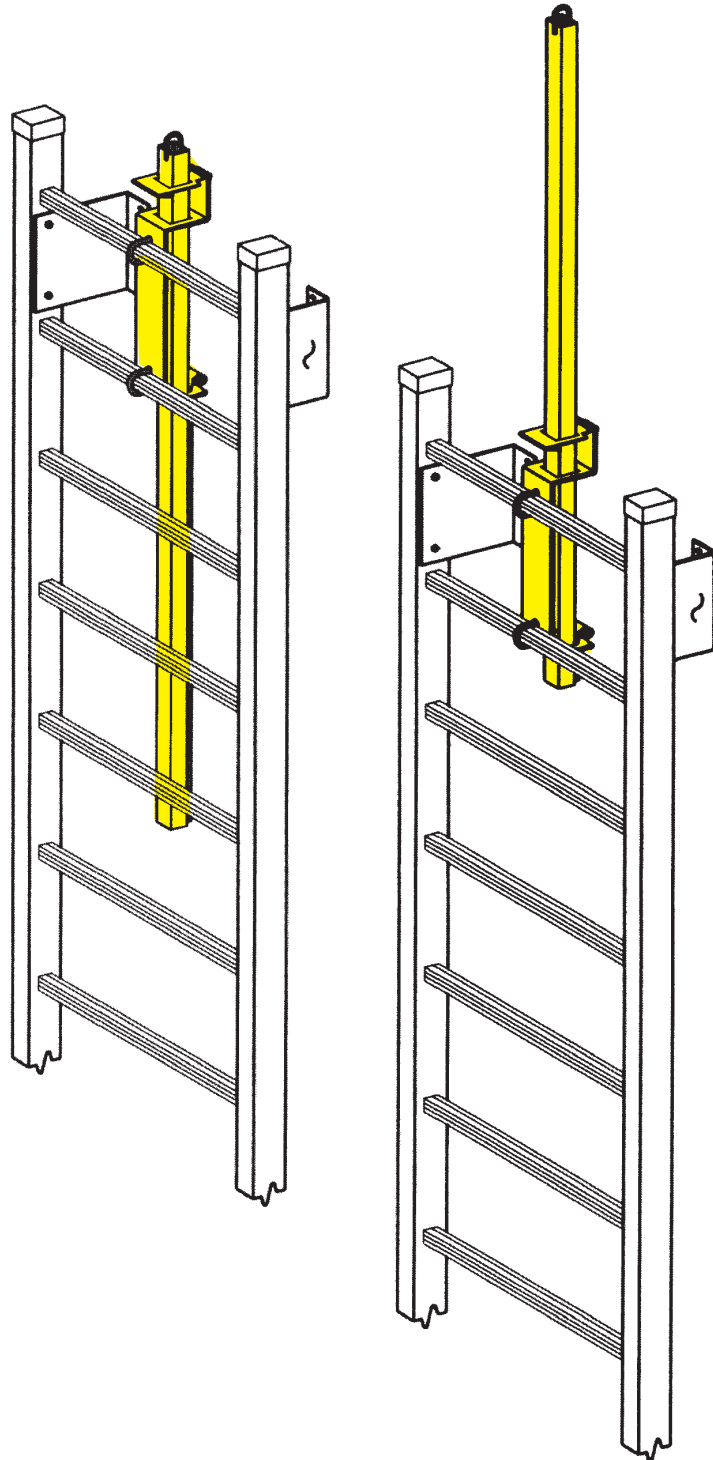

✓	Item No.	Material	Ship Wt. Lbs.
	WB Safety Post*	Steel	24

\* Stock item

Project: \_\_\_\_\_ Date: \_\_\_\_\_

Contractor: \_\_\_\_\_ Architect: \_\_\_\_\_

Sizes: \_\_\_\_\_ Quantity: \_\_\_\_\_ Approval Initials: \_\_\_\_\_



Phone: 1-800-255-5515 • Fax: 1-800-822-5001

[www.wbdoors.com](http://www.wbdoors.com)