

SUBMITTAL SHEET

WALLS & CEILING

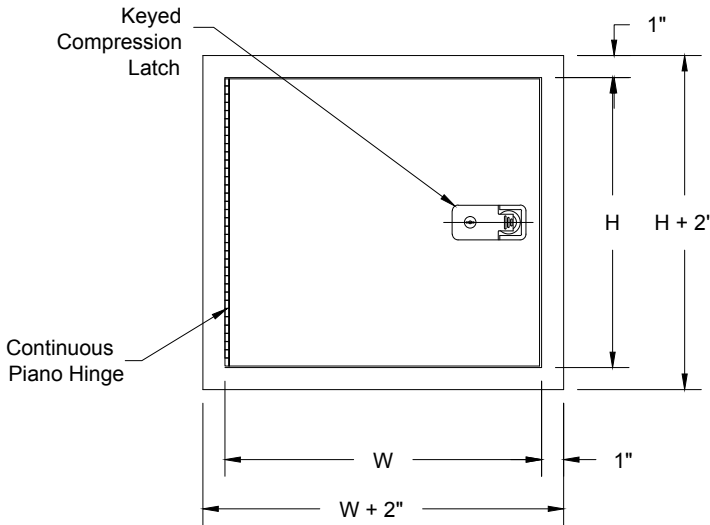

FRONT ELEVATION



SECTION DETAIL

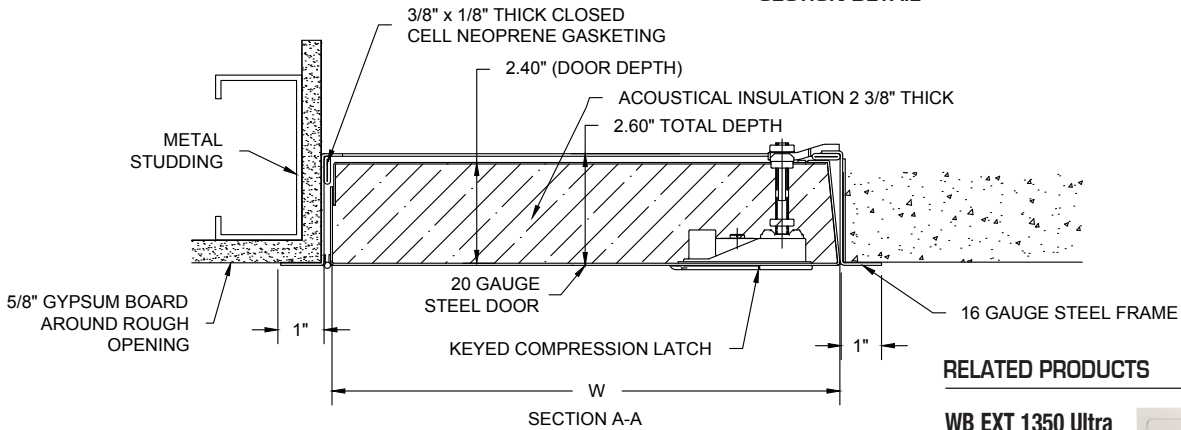

SPECIFICATIONS:

Door: 20 ga. steel

Trim: 16 ga. steel, 1" wide

Finish: Prime coat of rust inhibitive electrostatic powder, white baked enamel, **paintable surface**. Stainless steel available in No. 4 finish

Latches: Compression latch finished in chrome with cup sealed gasket, keyed

Hinges: Continuous piano hinge

Insulation: Acoustical insulation, 2 3/8" x 1/8" thick

Gasket: Between door and frame 3/8" wide x 1/8" thick closed cell neoprene gasketing

Application: For interior use

OPTIONS (at additional cost)

- Stainless steel No. 4 finish
- Special sizes available
- _____

✓	Model No.	Door Opening	Rough Opening	Ship Wt. Lbs.
	STC 650	12 x 12	12 3/8 x 12 3/8	7
	STC 650	14 x 14	14 3/8 x 14 3/8	8
	STC 650	16 x 16	16 3/8 x 16 3/8	10
	STC 650	18 x 18	18 3/8 x 18 3/8	11
	STC 650	24 x 24	24 3/8 x 24 3/8	16
	STC 650	24 x 36	24 3/8 x 36 3/8	19
	STC 650	36 x 36	36 3/8 x 36 3/8	29

Custom sizes available upon request.

Independently tested in accordance with ASTM:E1332, ASTM: E90, and ASTM: E413, and rated of STC 64 when installed according to manufacture's instruction. This sound rated access door is perfect for areas where sound needs to be eliminated such as multi-family buildings, schools, hospitals, apartments, and even residential use.

Project: _____ Date: _____
 Contractor: _____ Architect: _____
 Sizes: _____ Quantity: _____ App Initials: _____

1330 Progress Drive • Front Royal, VA 22630 • Phone: 1-800-255-5515 • www.wbdoors.com

RELATED PRODUCTS

WB EXT 1350 Ultra Series Exterior Access Door



WB AL 1500 Series Aluminum Access Door

