

SUBMITTAL SHEET

CEILING ONLY

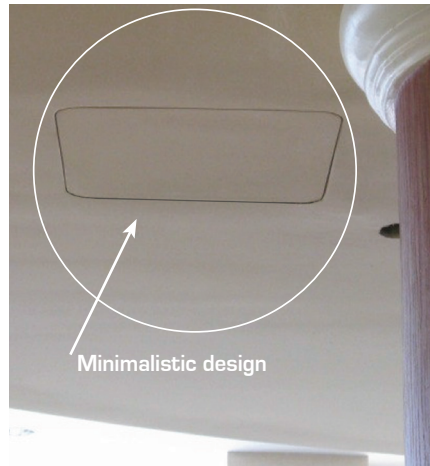

FRONT ELEVATION

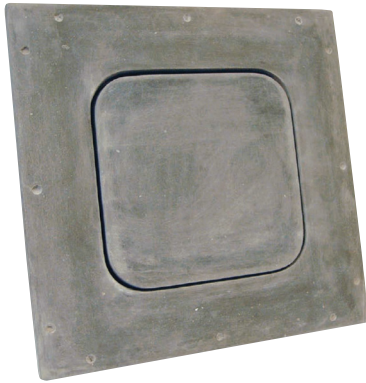
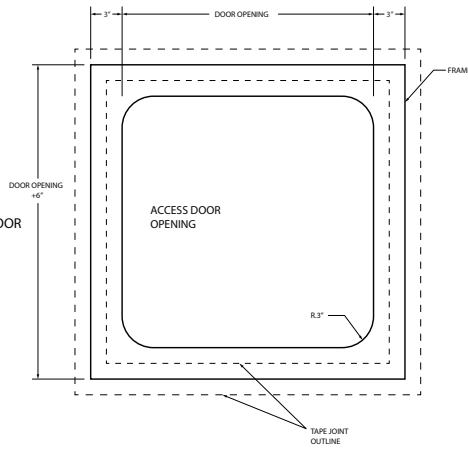
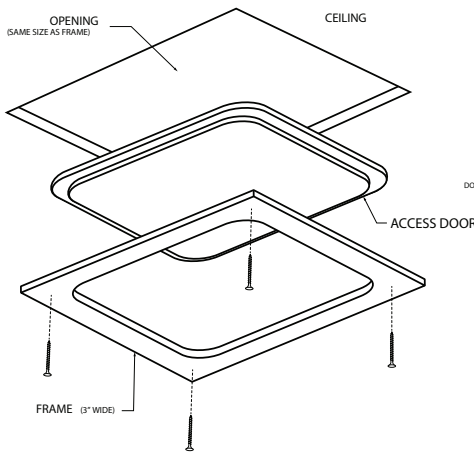

SECTION DETAIL

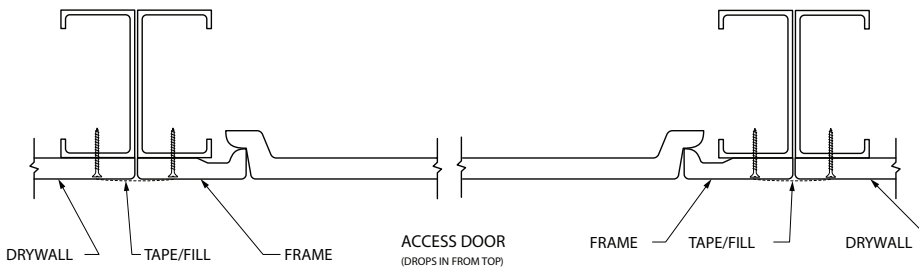

SPECIFICATIONS:

Glass-Fiber-Reinforced Cement (GFRC) panel, designed for exterior applications, including exterior soffits, porte-cochère, covered drive-up and any other location where you need discreet access and a weather-resistant panel. Showcasing a stealth appearance, tapered edge design that blends in seamlessly with surrounding. Williams Brothers offers a range of access opening sizes. Available in both drop-in and hinged.

Door & Trim: Glass-Fiber-Reinforced Cement (GFRC) based design can't rust and blends seamlessly with new or retrofitted drywall. Gasketing on 4 sides is standard

Finish: Unpainted natural GFRC, **paintable surface**, can be finished in stucco, plaster, or acrylic

Physical Properties: 1/8" to 3/16" shell thickness, Fastener test pull out (wood studs: 525 lbs. avg. and metal studs: 215 lbs. avg.). Fasteners push thru test: 350 lbs avg. Fuel Contribution (ASTM E84-80):0. Flame spread (ASTM E84-80): 0, Combustion (ASTM E84-80): non-combustible. Non-rated.

Installation: Access panels installed with standard supplies; screws are #6 buglehead, and joints use standard tape and joint compound. Substrate material is determined by the job-site.

OPTIONS (at additional cost)

- Ext GY Exterior Series Hinged (GY 3150, visit our website for sizes and submittal)

✓	Model No.	Door Opening	Rough Opening	Ship Wt. Lbs.
	EXT GY 3050	9 x 9	15 x 15	2.5
	EXT GY 3050	12 x 12	18 x 18	5
	EXT GY 3050	16 x 16	22 x 22	8.5
	EXT GY 3050	18 x 18	24 x 24	10
	EXT GY 3050	24 x 24	30 x 30	13
	EXT GY 3050	30 x 30	36 x 36	15

Custom sizes available upon request.

MSDS: Per OSHA HazCom per 29 CFR 1910.1200(b)(6)(iv): "Article" means a manufactured item other than a fluid or particle: (i) which is formed to a specific shape or design during manufacture; (ii) which has end use function(s) dependent in whole or in part upon its shape or design during end use; and (iii) which under normal conditions of use does not release more than very small quantities, e.g., minute or trace amounts of a hazardous chemical (as determined under paragraph (d) of this section), and does not pose a physical hazard or health risk to employees.

Project: _____ Date: _____
 Contractor: _____ Architect: _____
 Sizes: _____ Quantity: _____ App Initials: _____

1330 Progress Drive • Front Royal, VA 22630 • Phone: 1-800-255-5515 • www.wbdoors.com

RELATED PRODUCTS

**WB GY 3000 Series
 GFRG Drop-In Ceiling
 Access Panel**



AWCI ASSOCIATION OF THE WALL AND CEILING INDUSTRY

The World's Largest Access Door Store.™



BuyOnline
 WBCA 2024