

SUBMITTAL SHEET

WALLS & CEILINGS

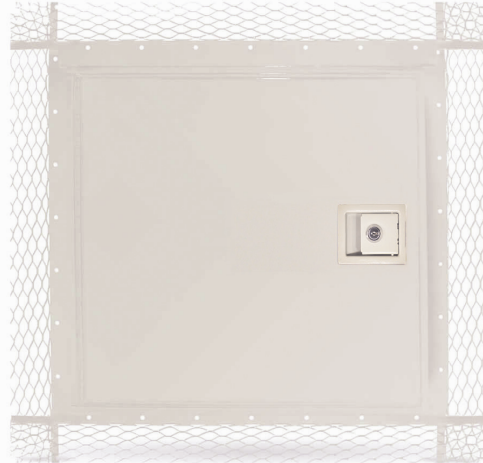

SPECIFICATIONS:

- Door:** 18 ga. gavanized steel
- Trim:** 18 ga. galvanized steel. These models have a 1" wide perforated flange of 22 ga. galvanized steel expansion bead with metal lath
- Hinge:** Continuous gavanized piano hinge
- Latches:** Paddle latch lock and slam catch
- Hinges:** Continuous piano hinge
- Insulation:** Double layer of 1" GreenGuard® Extruded Polystyrene insulation board, with R-Value @ 75°F Mean 5.0 x 2, FM approved*
- Gasket:** Open celled microcellular polyurethane on inside of door and closed cell neoprene sponge SC42 W/PSA stripping gasket on the back of the door
- Application:** For exterior purposes, weather resistive

Options: (additional cost)

- Special sizes available
- _____

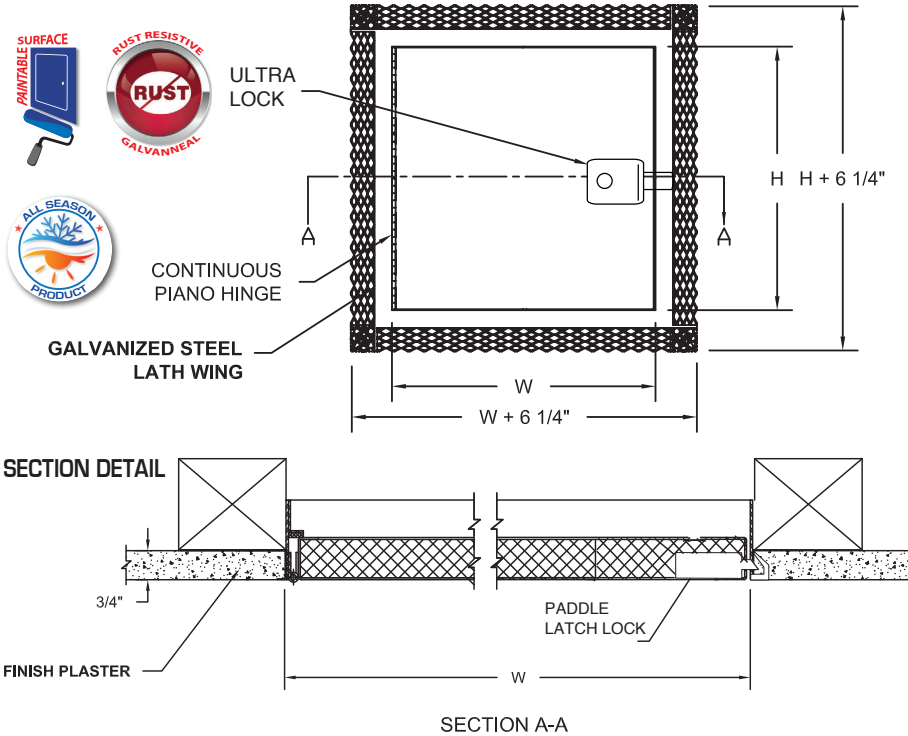

✓	Model No.	Door Size W x H	Wall Opening *	Ship Wt. Lbs.
	EXT-PL 1450	8 x 8	8 1/4 x 8 1/4	25
	EXT-PL 1450	12 x 12	12 1/4 x 12 1/4	27
	EXT-PL 1450	14 x 14	14 1/4 x 14 1/4	30
	EXT-PL 1450	16 x 16	16 1/4 x 16 1/4	35
	EXT-PL 1450	18 x 18	18 1/4 x 18 1/4	40
	EXT-PL 1450	22 x 30	22 1/4 x 30 1/4	45
	EXT-PL 1450	22 x 36	22 1/4 x 36 1/4	50
	EXT-PL 1450	24 x 24	24 1/4 x 24 1/4	55
	EXT-PL 1450	24 x 30	24 1/4 x 30 1/4	60
	EXT-PL 1450	24 x 36	24 1/4 x 36 1/4	67
	EXT-PL 1450	24 x 48	24 1/4 x 48 1/4	100
	EXT-PL 1450	30 x 30	30 1/4 x 30 1/4	65
	EXT-PL 1450	30 x 36	30 1/4 x 36 1/4	79
	EXT-PL 1450	30 x 48	30 1/4 x 48 1/4	85
	EXT-PL 1450	36 x 36	36 1/4 x 36 1/4	90

The WB EXT-PL 1450 Series Exterior Stucco Access Door is a durable, flush access panel designed for installation in exterior stucco walls and ceilings in applications where a concealed appearance is desired. Featuring an 18 gauge galvanized steel construction and a white baked, paintable enamel finish, door includes a weather and water resistant gasket plus 2" thick insulation with a R-Value of 5.0. In addition, with its concealed tape-in flange, door eliminates the visual distraction created by projecting, surface-mounted units.

1. When a door increases in size, more cams are added for security in the ceiling or wall
2. For requests on clear opening after door installed, please email info@wbdoors.com
3. All installation holes must be used for proper door functionality and security
4. For custom sizes, please reach out to info@wbdoors.com
5. Clear opening may be impeded by structural or functional parts on door
6. Drawings of any door can be requested through info@wbdoors.com

Project: _____ Date: _____
 Contractor: _____ Architect: _____
 Sizes: _____ Quantity: _____ App Initials: _____

1330 Progress Drive • Front Royal, VA 22630 • Phone: 1-800-255-5515 • www.wbdoors.com



AWCI ASSOCIATION OF THE WALL AND CEILING INDUSTRY

The World's Largest Access Door Store.™

