

**SUBMITTAL SHEET**

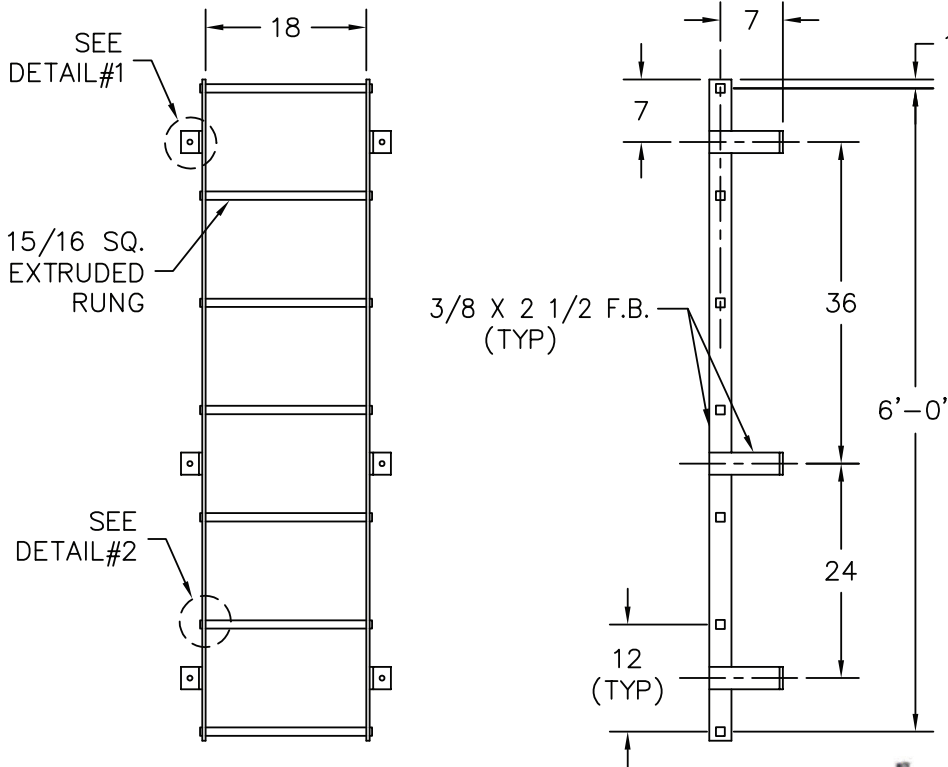

*Introducing Our Aluminum Wall Mounted Ladders*

Williams Brothers offers a complete line of aluminum wall mounted ladders, ideal to be used with any roof hatch. Ladder conforms to OSHA Standards 29CFR-1910.27.

For additional support this ladder can also be mounted to the floor using the optional floor bracket..

- Aluminum Wall Mounted Ladder
- 15/16" square extruded aluminum climbing rungs spaced on 12" centers
- Loading: 300 LBS at midspan
- 3/8" x 2 1/2" Aluminum Side Members
- 7" Stand-off brackets
- Mill Finish

**NOTE:** When accessing a roof from a building's interior consider combining the ladder with a Roof Hatch, Safety Post, Safety Grab or a WB Guard Rail system with self closing gate. This gives customers the option of a complete roof access system from a single source.

**OPTIONS:**

- Floor bracket
- Telescoping Saety Post
- 

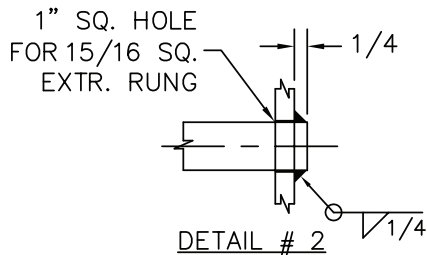
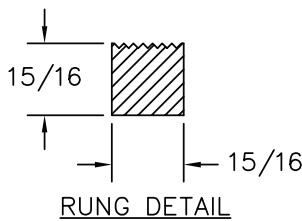
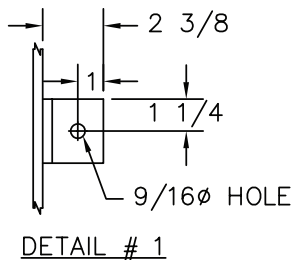

Model No.	Height (feet)
WB-AWML	5'
WB-AWML	6'
WB-AWML	7'
WB-AWML	8'
WB-AWML	9'
WB-AWML	10'
WB-AWML	11'
WB-AWML	12'
WB-AWML	13'
WB-AWML	14'
WB-AWML	15'

**RELATED PRODUCTS**

**WB-Safety Post**

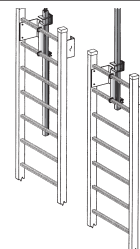

Project: \_\_\_\_\_ Date: \_\_\_\_\_

Contractor: \_\_\_\_\_ Architect: \_\_\_\_\_

Sizes: \_\_\_\_\_ Quantity: \_\_\_\_\_ App Initials: \_\_\_\_\_

1330 Progress Drive • Front Royal, VA 22630 • Phone: 1-800-255-5515 • [www.wbdoors.com](http://www.wbdoors.com)



*The World's Largest Access Door Store.™*



**BuyOnline**  
 WBCA 2023