

**SUBMITTAL SHEET**

**WALLS & CEILINGS**

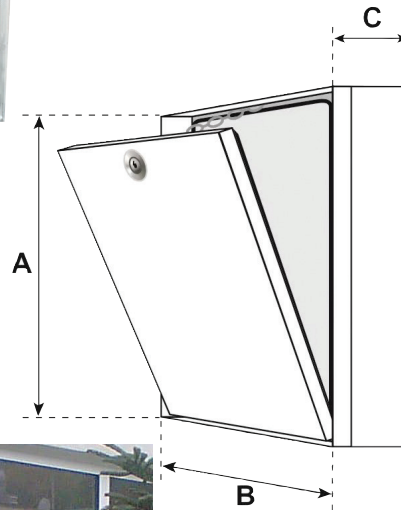

The **WB EXT-DWAL 1650** is a frameless watertight access door intended for exterior applications. The access panel consists of an aluminum frame, cement board, and a cylinder lock with key. The panel is fully removable from the frame with a safety cable to prevent against accidental openings. Once installed, the only thing visible is 3 mm gap. The **WB EXT-DWAL 1650** frameless watertight access door for tile is proudly manufactured for **The Williams Brothers Corporation of America**.

**SPECIFICATIONS:**

**Door & Frame:**

**Removable Door:** Fully detachable cement hatch/door with safety chain

**Finish:** Flush cement board

**Latch:** Cylinder lock and 2 keys

**Standard Features:**

- Easy assembly
- Solid aluminium frame
- Cement board
- Flush installation in ceilings and walls
- Watertight gasket

✓	Model No.	Door Size	Cut Opening	Ship Wt. Lbs.
	EXT-DWAL 1650	8x8	8 3/8 x 8 3/8	12
	EXT-DWAL 1650	10x10	12 3/8 x 12 3/8	14
	EXT-DWAL 1650	12x12	12 3/8 x 12 3/8	16
	EXT-DWAL 1650	14x14	14 3/8 x 14 3/8	18
	EXT-DWAL 1650	16x16	16 3/8 x 16 3/8	20
	EXT-DWAL 1650	18x18	18 3/8 x 18 3/8	22
	EXT-DWAL 1650	20x20	20 3/8 x 20 3/8	25
	EXT-DWAL 1650	24x24	24 3/8 x 24 3/8	28
	EXT-DWAL 1650	24x30	24 3/8 x 30 3/8	30
	EXT-DWAL 1650	24x36	24 3/8 x 36 3/8	36
	EXT-DWAL 1650	36x36	36 3/8 x 36 3/8	42

Custom sizes available upon request.

**RELATED PRODUCTS**

**WB DW 400 Series for Drywall**



Project: \_\_\_\_\_ Date: \_\_\_\_\_  
 Contractor: \_\_\_\_\_ Architect: \_\_\_\_\_  
 Sizes: \_\_\_\_\_ Quantity: \_\_\_\_\_ App Initials: \_\_\_\_\_

1330 Progress Drive • Front Royal, VA 22630 • Phone: 1-800-255-5515 • [www.wbdoors.com](http://www.wbdoors.com)



*The World's Largest Access Door Store.™*

